

Instruction



Table of Contents

1.1 The User Manual..... 2

1.2 Technological background ..... 2

1.3 Plant observation ..... 3

1.4 Testing ..... 3

1.5 Operation with timer..... 5

1.6 Technical data..... 6

Appendix A. General Information ..... 7

Appendix B. Fundamental Safety Regulations..... 8

## Instruction

### 1.1 The User Manual

This instruction is applicable for the UniRo 50 plant with timer. Guldager A/S has aimed to provide an adequate survey and thorough information about the use of this plant. The instruction should be read carefully, before the plant is put into service. Please, note that the enclosures at the rear of this manual give important information about copyright, guarantee as well as safety directions. Should you have questions to this manual or the use of the plant after reading this material, please do not hesitate to contact us:

Guldager A/S

Hejrevang 1-3

DK-3450 Allerød

Phone: + 45 48 13 44 00

E-mail: [guldager@guldager.com](mailto:guldager@guldager.com)

Homepage: [www.guldager.com](http://www.guldager.com)

### 1.2 Technological background

The UniRo plants make use of the reverse osmosis (RO) filtration principle, in which water is passed at high pressure through a membrane, only water molecules can pass through the membrane, as all salts will be separated from the clean water. Almost 100% of the dissolved salts are retained and even micro organisms, bacteria and pyrogenes are retained. The pure water (permeate) is lead to a reservoir tank, from where it is pumped to the place of consumption.

The pureness of the permeate depends on the quality of the water to be treated. If the raw water is normal drinking water the conductivity of the treated water will typically be approx. 10  $\mu\text{s}$ , this is more or less equal to the conductivity of distilled water.

Reverse osmosis is environment friendly. No chemicals are used in the process – only water pressure.

## Instruction

### 1.3 Plant observation

The softening unit and RO plant must be in operation at all times. The RO plant has been adjusted to softened water, and the membranes will calcify, if the plant is supplied with hard water.

### 1.4 Testing

#### 1.4.1 Water Sample

On a regular basis, the quality of the softened water must be checked. This can be done with a water test set, which can be supplied by Guldager A/S. See instruction on the test kit.

#### 1.4.2 Salt

Check the salt level in the salt tank, and that salt is being consumed. Do not fill with salt until the salt has reached the water level, as otherwise insoluble clods can be formed. Often salt contains indissoluble substances. Consequently, the tank must be emptied and cleaned regularly, depending on consumption, but at least twice a year.

Use only salt which has been approved for softening units (tablets only).

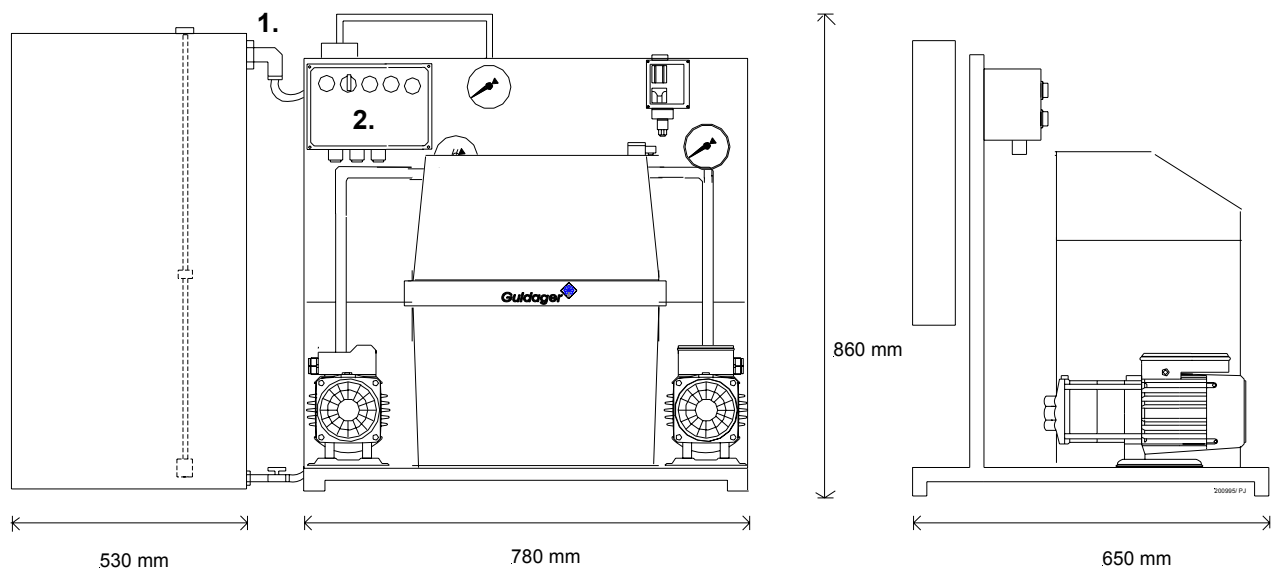

## Instruction

### Installing the plant

1. When the plant has been properly connected to the electric mains, performed by the contractor (cold water connection  $\frac{3}{4}$ ", drain and electric connection) the built in softening unit can be activated. The hardness level of the raw water must be checked and salt tablets filled. See user manual for softening unit.
2. Before start-up of the RO plant, the left relay in the control unit is removed (the product pump is not running), then press the green button, which will then shine. After approx. 30 seconds the high pressure pump will set in, and osmosis water will be produced.
3. Adjust the operating pressure on the needle valve to 15 bar.
4. Adjust pressure to the product pump on the pressure switch to 3 – 3.5 bar.
5. While the reservoir is filled, the following is to be checked:
6. Free outlet for concentrate from membrane. Soft water control – after the softener the water must be 0 °dH. See user manual for softening unit.
7. Check function of level switch in the reservoir.
8. Lead the overflow of the softening unit and reservoir to drain.
9. Ventilate the product pump by unscrewing the upper square head bolt. Equip with sealing material. Do not tighten the screw until water overflows.
10. Now switch on the permeate, the left relay is replaced and the plant is switched on, now both buttons will shine. After 1 minute the high pressure pump will set in. The yellow test lamp turns off.
11. Consumption of permeate can be activating the plant which is connected after the RO plant (e.g. a dish washing machine).

**When the reservoir is filled with water the plant is activated and ready for use. The plant is in "stand by" position and will automatically set in again, when water is being consumed.**

**Instruction**

**1.5 Operation with timer**

1. Empty the reservoir tank.
2. The permeate hose is lead to drain (1), see dimensioned drawing.
3. The revolving switch is turned to the right to the blue lamp on the panel (2), see dimensioned drawing
4. The plant now operates with timer and the blue lamp shines.

In order to clean the membranes the RO plant will run for 2 hours per week. When the plant is to run in normal operation the permeate hose is re-established and the revolving switch is turned to the left.

Furthermore, the plant is equipped with micron and carbon filters, which are mounted on the inlet (raw water). If the pressure drop is more than 1 bar the filters must be exchanged.

<b>MicroRex T31</b> 037 52 <b>MicroRex W31</b> 037 54	<b>MicroRex T31</b> 037 56 <b>MicroRex W31</b> 037 57	<b>MicroRex QT31</b> 037 53 <b>MicroRex QW31</b> 037 55	<b>MicroRex QT31</b> 037 51 <b>MicroRex QW31</b> 037 58
230V~ 50Hz	120V~ 50Hz	230V~ 50-60Hz	120V~ 50-60Hz
		R100h	R100h
16A/250V-μ cosφ = 1	16A/250V-μ cosφ = 1	16A/250V-μ cosφ = 1	16A/250V-μ cosφ = 1

Parallelkompensation:	C ≤ 14 μF	Kompensere parallel:	C ≤ 14 μF
Compensé parallèle:	C ≤ 14 μF	Filmalkoiskompensointi:	C ≤ 14 μF
Parallel compensation:	C ≤ 14 μF	Paralleli Kompensering:	C ≤ 14 μF
Parallelkompensatie:	C ≤ 14 μF	Parallellkompenserad:	C ≤ 14 μF
Precisione dell'orologio:	C ≤ 14 μF	Compensado em paralelo:	C ≤ 14 μF
Compensacion paralelo:	C ≤ 14 μF	Παράλληλη αντιστάθμιση:	C ≤ 14 μF

Automatik

**MicroRex T31**  
**MicroRex QT31**

min. 3 x 15'

18 17 16 15 14 13 12 11 10 9 8 7 6

**MicroRex W31**  
**MicroRex QW31**

min 3x 2h

18 12 6 18 12 6 18 12 6

7 6 5

## Instruction

### 1.6 Technical data

<b>Raw water temperature</b>	10-15 °C
<b>Max. operating temperature</b>	25 °C
<b>TDS product water (permeate)</b>	20-30 mg/l
<b>Design TDS salt content in feed water</b>	500 mg/l
<b>Raw water consumption</b>	0,050-0,250 m³/h
<b>Product water capacity (permeate)</b>	50-250 l/h
<b>Water utilization factor (softened)</b>	75%
<b>Pressure pipe, type</b>	Brass 2½", 20 bar
<b>Pressure pipe, number of</b>	1-5
<b>Element, type</b>	Thin film 2521
<b>Elements, number of</b>	1-5
<b>pH value</b>	6-7
<b>Pressure, max.</b>	15 bar
<b>Temperature, max.</b>	25 °C
<b>Potential</b>	220V/50 Hz
<b>Plastic materials in modules</b>	Epoxy/glass composite
<b>Installed output</b>	1,3 kW/h
<b>RO pump, capacity</b>	750 l/h
<b>RO pump, operating pressure</b>	15 bar
<b>RO pump, type</b>	Grundfos/Procon
<b>RO pump, output</b>	0,71 kW/h
<b>Product pump, capacity</b>	1 m³/h
<b>Product pump, type</b>	Grundfos/ CH2-50
<b>Product pump, output</b>	0,75 kW/h
<b>Reservoir</b>	60-200 l

## Instruction

### Appendix A. General Information

#### Copyright

This instruction is intended solely for buyers of UniRo systems and their staff. All copyrights belong to the company Guldager A/S. Replication is allowed for internal use only. This permission applies for the safety directions exclusively. Copying of drawings and diagrams is NOT allowed.

#### Guarantee and Responsibility

For a period of 12 months, Guldager A/S guarantees all the mechanical and electrical parts of the system as well as its mechanical construction. This guarantee is valid from the date of transfer. Within this period all parts that cannot be used due to faulty construction, defective material, or defective condition are repaired or replaced.

Guldager A/S cannot be held responsible for damages caused by the delivery after the transfer:

- a. on real property or movables that occur while the delivery is in the buyer's possession.
- b. on products, which have been produced by the buyer, or on products, of which these are a part, or for damages on real property or movables, caused by these products as a consequence of the delivery.

In no case the supplier can be held responsible for loss of profits, or other financial consequential losses.

#### Staff Obligations

Before work is started, anyone, who has been charged with working with this system, is under the obligation to

- observe the basic instructions for working security and the prevention of accidents.
- read Appendix B.

## Instruction

# Appendix B. Fundamental Safety Regulations

### Observe the Instructions

In order to be in a position to handle the plant in a correct and safe way, and to make sure that it will work to the utmost without interruption, you must possess knowledge of the fundamental safety regulations and instructions.

This appendix lists the most important precautions for a correct and safe handling of the system. This instruction incl. its safety regulations must be observed by anyone, working with or near the plant. Safety regulations – including the company's internal safety regulations must be observed.

The user manual must be stored in visible distance to the area, where the operators control the plant, and safety regulations and warnings must be placed close to the plant on a permanent and visible spot.

### The Company's Obligations

The company is under the obligation to let only personnel that meet with the following demands work with and around the system, i.e. personnel who has

- been instructed in the use of the system.
- read this appendix about fundamental safety regulations.

### Constructional Changes of the Plant

- No changes, additions or reconstructions of the plant are to be made without the producer's written permission.
- Only genuine spare parts and abrasive parts are to be used.
- If non-genuine parts are built in, the guarantee no longer applies.

## Instruction

### Inspection of the Plant

On demand, the employer must take care that the device undergoes a safety inspection. This, however, must be done at least once a year. The inspection is to be carried out by an expert and a report on the inspection results must be written.

An expert is defined as somebody, who, on the basis of his professional education and knowledge, possesses thorough knowledge of the tool in question, and is familiar with the relevant national occupational safety regulations, regulations for the prevention of accidents, directives, safety rules, and technical rules, which have been generally approved (i.e. DIN norms, VDE rules) to such an extent that he/she is able to estimate the safety condition of the tool. These demands are met by e.g. the service staff from Guldager A/S and by personnel with corresponding education.

### Dangers by Handling the Plant

This plant has been constructed according to the present technological development and the present technical safety rules. In spite of this, by unskilled use situations that are dangerous to the operator and others and damages to the plant and other damages on material may occur. The plant is only to be used for its normal purpose and in good and safe condition.

Defects, which have an influence on safety, e.g. leaks on pressurized parts and other similar elements of danger, must be repaired immediately in a professional, correct way.

### Remaining Risks

In spite of all safety precautions, protective outfit and the optimal organizational precautions, material or even personal damages cannot be excluded.

Should an accident occur, Guldager must be informed. In order to minimize potential remaining risks or completely eliminate these through technological progress we aim to react on even the smallest irregularity within the terms of our duty to supervise our products.